



How-To Guide

Raised Planters

The following guide outlines how to build one 22" tall, 2' wide, 6' long wooden raised bed, however the same principles described in this guide apply to custom building raised beds at different dimensions.

Duration



1/2 Day

of People



2 - 4

Required Effort



Moderate/high level of effort

Diagram

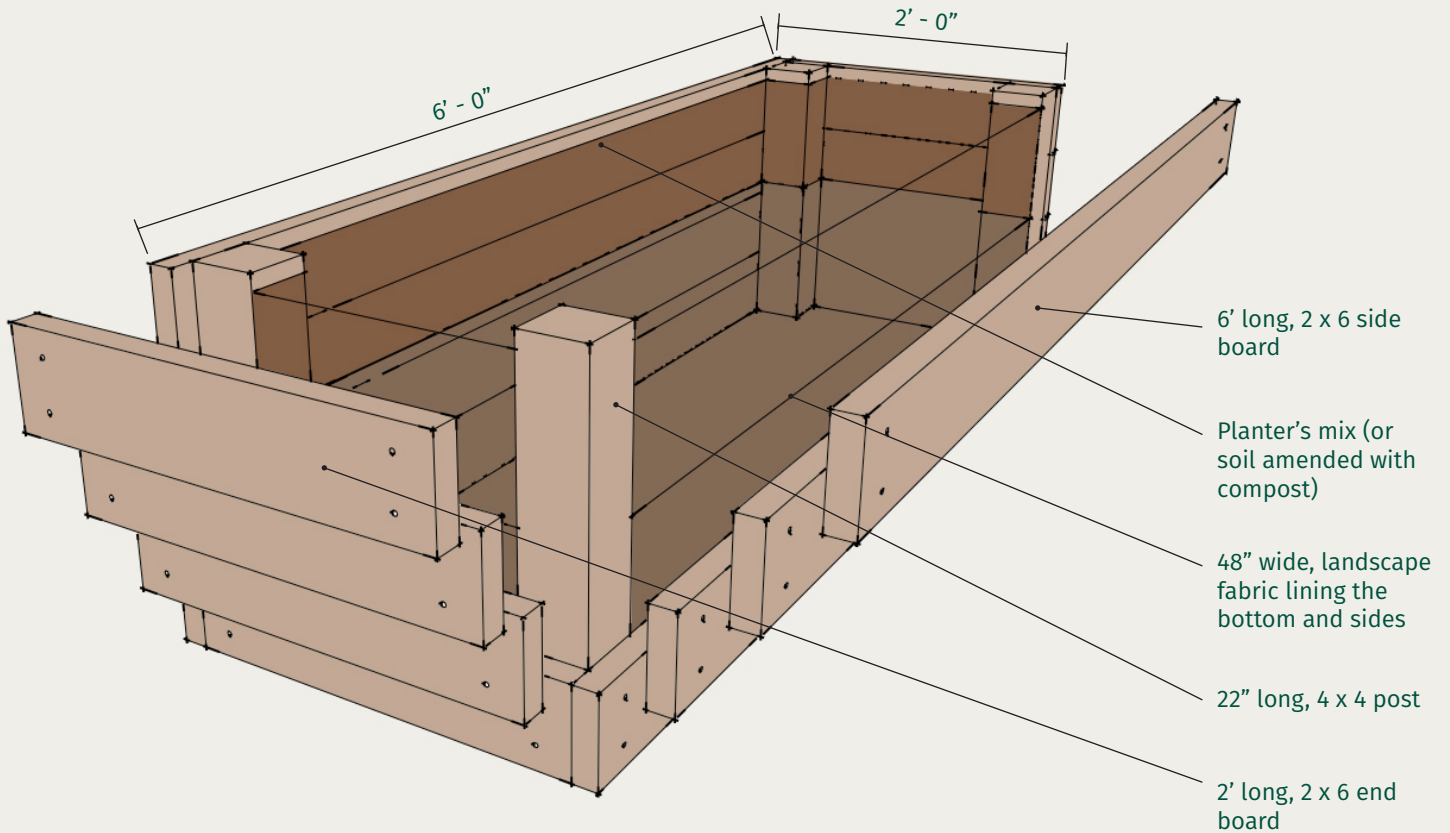

Materials

- (1) 8' long Cedar 4 x 4 (actual 3.5" x 3.5"), cut into 22" long posts
- (8) 8' long, Cedar or Douglas Fir boards, 2 x 6's (actual 1.5" x 5.5")
- 3", #10 coarse thread exterior wood screws
- Landscape fabric - 48" wide
- (1) cubic yard - Planter's Mix soil or equivalent (amended soil with compost, ready to plant in)
- Heavy grit sand paper (40 - 60 grit)
- Staples
- Non-toxic, water-based wood sealant
OR Durable, non-toxic outdoor paint
- Access to water
- (Optional) Mulch
- (Optional) Hand-rails

Plants

- Edible plants: herbs, veggies, and small fruit**
- Flowering annuals**
- Flowering native perennials**
- Small grasses**

Tools

- Miter or circular saw
- Extension cord with access to power
- Screw gun/drill
- Proper screw bits
- Pencils
- Speed square
- Orbital power sanders
- Paint brushes
- Paint rollers
- Paint trays
- Tarps
- Staple gun
- Utility knife or scissors
- Flat and spaded shovels
- Pushbroom
- Wheelbarrows
- Garden hose
- Eye and ear protection



Implementation Steps

1 Gather materials

2 Build the box

- Prep the posts: Cut the 4 x 4 into 4, 24" lengths.
- Prep the sides: Cut 24" off of the 8' long 2 x 6s - This will create 8, 2' long end boards, and 8, 6' long side boards.
- Assemble the frame fastening the side boards to the posts with the 3" long wood screws. Ensure the ends of the board are flush to the outside edge of each post, allowing for the side boards to ultimately be flush with the outer face of the end board. (See diagram)

3 Sand any sharp edges, splinters, or snags

- Be sure to round any pointy corners.

4 (Optional) Install hand rail

- If providing a hand rail to be used as a pull-up bar for infants and toddlers, make sure hardware follows Licensing or school requirements for safety and tamper resistance.

5 Weatherproof or paint

6 Place in desired location

- Ensure location is as level as possible before placing.

7 Line the bottom of the box

- Cut the landscape fabric at 8' long. This will allow for the fabric to wrap up the inside walls 12" on all sides. Staple to attach.

8 Fill the planter with soil

9 Plant

10 (Optional) Add mulch to conserve moisture

11 Water thoroughly!

- IMPORTANT: Once planted, IT IS CRITICAL to water each plant at its base for a minute or so until the soil is fully soaked and saturated.

Considerations

- Bed heights typically vary between 6" to 30".
- Cedar is more expensive than Douglas Fir, but will last longer as it has a natural resistance to decay and rot. Composite lumber, although expensive, will last longest.
- When using standard treated landscape lumber, it is recommended to use new material rather than old or repurposed lumber, due to the chance of hazardous chemicals being present. Note that railroad ties should not be used for beds intended for edible plants as they may contain chemicals that leach into the soil.
- For beds with sides longer than 6', supporting rebar, or another post can be placed along the center of the length to prevent the bed from bowing outward.
- If placing the bed on concrete, consider adding an impervious liner between the boards and the soil to prevent leaching and staining of the concrete surface underneath.
- **Calculating the necessary amount of soil for raised planters:**
 - Area of bed in square feet x (depth in inches/12) = Amount in cubic feet/27 to convert to cubic yards x 1.1 for loss in transit and settling = Needed cubic yards
 - Example for a 22" tall, 2' wide, 6' long raised planter:
 $2' \times 6' = 12 \text{ sf} \times (22"/12) = 22/27 \times 1.1 = .8963 = 1 \text{ cy rounded up}$
- Use compost that has been properly cured, to amend the soil each season.
- Painting the sides of raised planters can be a great way to get children involved and add a splash of color to the outdoor learning environment.
- Hand rails, to be used as pull-up support for infants and toddlers, can be purchased used from Habitat for Humanity ReSource, or other similar reused materials provider.
- It is recommended to avoid using regular potting soil in wooden raised beds as it does not retain moisture well. Instead, use a high quality Planter's Mix or amended soil with compost, ready to plant in.



Cover photo credit:
NLI

Disclaimer

Before installing new play and learning components in your outdoor learning and play space, please check with local regulatory agencies to ensure compliance with health and safety requirements. While the intent is to provide a general resource for reconnecting children to nature, the authors and program sponsor disclaim any liability based upon this information. PLAE Inc. assumes no responsibility for the design or installation of outdoor components for play and learning. In no event will PLAE Inc. be liable for any loss or damage including without limitation, indirect or consequential loss or damage incurred during the construction or use of the outdoor learning environment.

For more outdoor project ideas, visit:
www.plaeinc.org/ECHO